



雷虎生技股份有限公司

 Manufactured by

TTBIO CORP.

台中市40755工業區六路7號2F
2F.,NO.7, 6TH ROAD INDUSTRY PARK
TAICHUNG, TAIWAN 40755
TEL:886-4-23595958
FAX:886-4-23596893
E-mail:medical@ttbio.com
Website:www.ttbio.com
許可證字號:衛署醫器製壹字第004431號

EC REP

CMC MEDICAL DEVICES & DRUGS S.L.
C/ Horacio Lengo N18.
CP29006,Málaga Spain

售后服务:上海汉瑞祥贸易有限公司
地址:上海市延安西路1358号4B-1室
电话:021-32231198
传真:021-32231196

生产商:雷虎生技股份有限公司
注册地址:台中市西屯区协和里
工业区六路七号2F
生产地址:台中市西屯区工业六路七号2F
电话:886-4-23595958
传真:886-4-23596893
邮箱:medical@ttbio.com
网址:www.tbio.com

Content are subject to change without prior notice. **0JL0138V2**

2016.12

TTBIO *Bettering your life!*

Automatic Handpiece Maintenance Unit

手機自動保養機操作說明書



TTcare 100+

Instruction Manual

Thank you for purchasing the TTcae 100+, a dental handpiece maintenance unit.
The TTcae 100+ lubricates and internally cleans dental handpieces easily and effectively.
For optimum safety and performance, read this manual thoroughly before using the unit and pay close attention to the warnings and notes.
Keep this manual in a handy place for future reference.

感謝您購買TTcae100+牙科手機自動保養機。

TTcae100+ 能有效的清潔與潤滑牙科手機的內部結構。
為了獲得最佳的安全性和性能，使用本機前請閱讀本手冊，並密切注意所有的警告符號和意義。
請將本手冊放在一個方便拿取的地方，以利隨時參考。

感谢您购买TTcae100+牙科手机自动保养机。

TTcae100+ 能有效的清洁与润滑牙科手机的内部结构。
为了获得最佳的安全性和性能，使用本机前请阅读本手册，并密切注意所有的警告符号和意义。
请将本手册放在一个方便拿取的地方，以利随时参考。

PRECAUTIONS 01

DISCLAIMER 02

1. Warnings, Cautions and Notes 02

2. Specifications 03

3. Parts Identification 06

4. Setup 08

5. Operation 10

6. Maintenance and Replacement Parts 13

7. Maintenance and Inspection 16

8. Trouble shooting and Error Code 17

9. Tools and Consumables 19



10. Service Contacts 20

11. Information on Electromagnetic Compatibility 21

PRECAUTIONS

Most operation and maintenance problems result from insufficient attention being paid to basic safety precautions and not being able to foresee the possibilities of accidents. Problems and accidents are best avoided by foreseeing the possibility of danger and operating the unit in accordance with the manufacturer's recommendations. First thoroughly read all precautions and instructions pertaining to safety and accident prevention; then, operate the equipment with the utmost caution to prevent either damaging the equipment itself or causing injury.

Note the meaning of the following symbols and expressions:

	WARNINGS	This warns the user of danger of death, serious injury or total equipment damage and failure or fire.
	CAUTIONS	This identifies methods not to be used or purposes which the instrument is not suited for.
	NOTES	This alerts the user to the risk of light to medium injury or equipment damage.

■ **Note**
 This alerts the user of important points concerning operation.
 The user (i.e. clinic, hospital etc.) is responsible for the management, maintenance and use of medical devices. Also this equipment must not be used by anyone except legally qualified dentist or doctors.

Do not use this equipment for anything other than its specified purpose.
--

■ **Caution:**
 Federal law restricts this device to sale by or on the order of a dentist (for U.S.A.).

ATTENTION

TTBIO CORP. will not be responsible for accidents, instrument damage, or

- (1) repairs made by personnel not authorized by TTBIO CORP.
- (2) any changes, modifications, or alterations of its products.
- (3) maintenance or repairs using parts or components other than those specified by TTBIO CORP. and other than in their original condition
- (4) operating the instrument in ways other than the operating procedures described in this manual or resulting from the safety precautions and warnings in this manual not being observed
- (5) workplace conditions and environment or installation conditions which do not conform to those stated in this manual such as improper electrical power supply
- (6) fires, earthquakes, floods, lightning, natural disasters, or acts of God.

1. Warnings, Cautions and Notes



WARNINGS

- Explosion Hazard. Do not use near open flames or other ignition sources.
- Health Hazard. The area must be well ventilated. Breathing fumes could damage your health.
- The equipment must be properly grounded.
- Make sure the ground is properly connected.
- To prevent the spread of grave, life-threatening diseases like HIV and hepatitis B, autoclave handpieces after performing regular maintenance using the TTcare 100+.
- Avoid the risks of electrical shock, equipment damage and fire during an electrical storm: Turn the TTcare 100+ off and do not touch it or its cord.
- Wear surgical gloves, mask and protective eyewear to operate and clean the TTcare 100+.



CAUTIONS

Electromagnetic wave interference caused by cellular phones, transceivers, remote controls and similar transmission devices could cause the equipment to operate randomly. All devices which transmit electromagnetic waves located near the work area should be turned off.



NOTES

- Set the TTcare 100+ on a level and stable surface.
- Depending on the type of handpiece and coupling, there could be a release of oil mist. In this case, lower the pressure to 4 bar.
- Oil will leak or spray out if the cans are not properly installed.
- Make sure the head is flat against the nozzle guide. If it is tilted, the nozzle might be bent or oil might spray out.
- Oil will spray out of the chuck nozzle if the handpiece is removed too soon (before the beep).

- For some handpieces, an oil mist may be released if a burr is not inserted.
- Do not damage the o-ring on the coupling when attaching a handpiece. This could result in oil spraying out or poor performance.
- Do not select a coupling that does not have a handpiece attached to it. This would result in oil spraying out when the Start Switch is pressed.
- If the unit will not be used for a while, unplug it and close the main air valve.
- Please insure you use the correct adaptor for the instrument.
- Do not use couplings made for maintenance equipment other than the TTcare 100+. This could result in release of oil mist or poor handpiece maintenance.
- Dispose of used oil pads according to regulations for medical waste.
- Do not fail to push the tray all the way in. Otherwise, oil could leak out or oil mist might be released.

2. Specifications

Name	TTcare 100+
Rating	AC 100-240 V 50/60 Hz
Power Consumption	60VA max.
Fuse	250V 2A Slow Blow Type
Air Pressure	4~6 bar
Recommended Air Pressure	4 bar
Air Flow Rate	40 NL/ min
Weight	Approx. 9 kg
Size (including regulator)	Width 295 × Height 385 × Depth 295 mm
Protection category (Dust-proof; water-proof)	IP20

Operating environment	
Ambient temperature	Permitted in interior rooms
Temperature	15 to 40°C (59 to 104°F)
Humidity	25 to 90 %
Max. altitude	2000 m (6560 feet)

Transportation and storage conditions	
Temperature	-20 to 70°C (-4 to 158°F)
Humidity	5 to 95 %
Atmospheric pressure	700 to 1060 hPa

■ **Product Description**

Used to maintain optimum performance and prolong working life of dental handpieces.
 Delivers oil and air automatically to handpiece.
 Used after dental treatment and before autoclaving.

■ **Disposal**

The wastes incurred are to be recycled or disposed of in a way that is harmless for human beings and the environment; in doing so, the national valid regulations are to be observed.
 Disposal of equipment and accessories at the end of their service lives:
 On the basis of EC Directive 2002/96/EC on Waste Electrical and Electronic Equipment, we would like to point out that this product is currently in compliance with the labelling requirements but is not yet subject to the disposal requirements of this Directive. However, the unit may be disposed of in Europe in special waste management centers. Additional information can be obtained from the manufacturer or your dental supplier.

■ **Meaning of the Symbols**

• Device Label

TTBIO **TTcare 100+**
 Automatic Handpiece Maintenance Unit
 TTBIO CORP.
 2F, No.7, 6th Road Industry Park Taichung, Taiwan 40755
 Product code : 08090012XXX
 SN XXXXXXXXXXXX

INPUT :AC 100~240V 50/60 Hz
 60VA max.
 AIR PRESSURE: 4~6 bar
 FUSE: 250V 2A Slow Blow Type

CE, IP20, Warning, Info, Disposal symbols.



WARNING

- The blister can be cleaned with 30°C±5°C tap water or 60% to 70% alcohol, non-high-temperature cleaning.
- The blister can be used repeatedly, but should be changed once broken.

FLAMMABLE

- Spray cans will explode if they get too hot.
- Do not expose the spray cans to heat.
- Only use approved spray can.

*** PREVENT EXPLOSION AND IGNITION OF SPRAY CANS!**

• Appearing on the device

	Observe operator's manual	SN	Serial Number
	Date of manufacture		Warning
	Disposal information, see important information " Disposal"		Flammable

IP20	Protection category Dust-proof; water-proof		Eye protection must be worn
-------------	--	--	------------------------------------

• Carton Label

TTBIO **TTcare 100+** **CE**
TTBIO CORP.
 2F, No.7, 6th Road Industry Park Taichung, Taiwan 40755
 Product Code:08090012 SN XXXXXXXXXXXX

Automatic Handpiece Maintenance Unit

Storage and transport requirements

Temperature range: -20°C to 70°C
 Air Pressure: 700 hPa to 1060 hPa
 Humidity: 5% to 95%

Transport upright, Fragile, Stacking restriction (20 kg), Keep dry, Waste Disposal.

• Appearing on the packaging

	Fragile		Air pressure
	Keep dry		Humidity
	Transport upright		Quantity
	Stacking restrictions		Manufacturer
	Temperature range		

■ **Main Switch**

	OFF		ON
--	------------	--	-----------

3. Parts Identification

■ Introduction

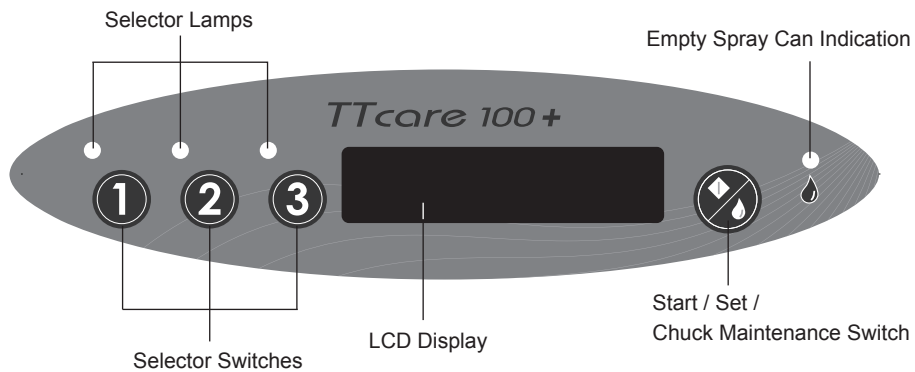
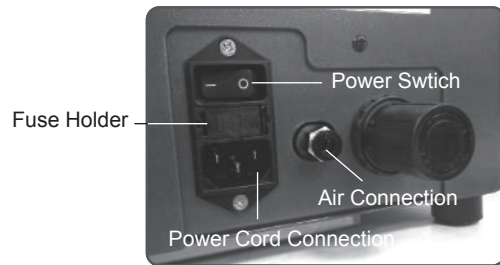
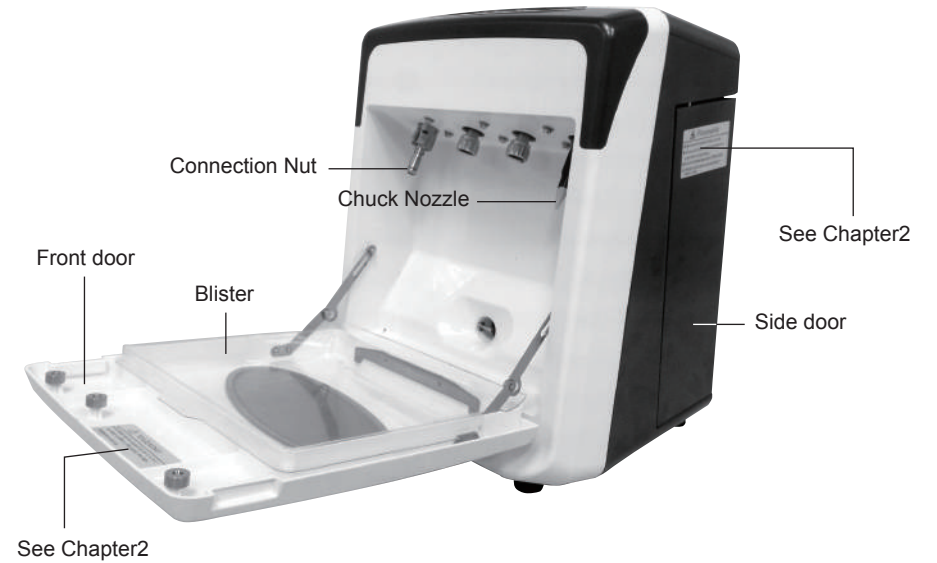

■ Components

<p>Main Unit</p>	<p>Blister (CODE No. 0PL0350)</p>	<p>Absorption pads (CODE No. 0PL0351)</p>
<p>Oil Tray (CODE No. 0PL0359)</p>	<p>Air Tube (CODE No. 0PL0360)</p>	

- * TTcare 100+ contains above standard components.
- * Optional components see chapter 9.

4. Setup

■ Note

Leave at least 5 cm (2 in) of free and open space around the TTcare 100+.

(1) Air Connection

1. Connect the air tube to the air connection and the main air supply.

Turn on the valve for the main air supply.

■ Note

The main air supply must be clean and oil-free. Make sure the tube is securely connected.

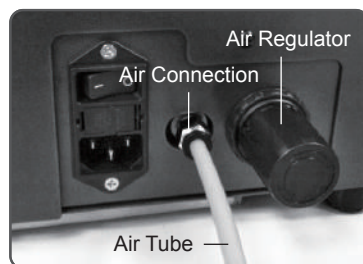

2. Set the air regulator dial between 4 and 6 bar.

Recommended Air Pressure is 4 bar.

■ Note

Less than 4 bar or higher than 6 bar will result in an error code.

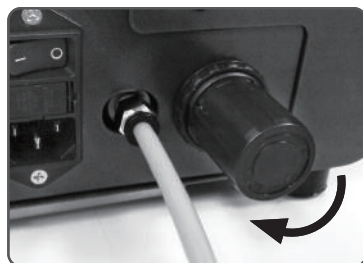

(2) Power Cord

Connect one end of the power cord to the main unit and plug the other end into the electrical supply.

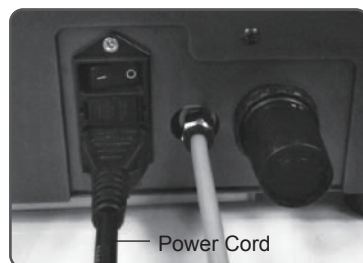

(3) Adapter

Fit the adapter into the nozzle and fasten the nut.

■ Note

Make sure the nut is securely tightened. Otherwise oil and air will escape and cause incorrect maintenance.

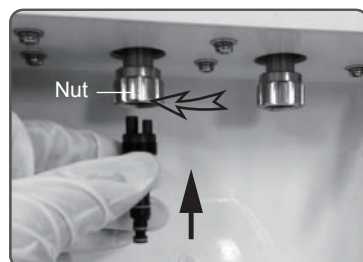

- (4) Tray
Place two Absorption pads in the tray and slide it into place.

■ Note

Slide the tray all the way in; otherwise, it might leak.

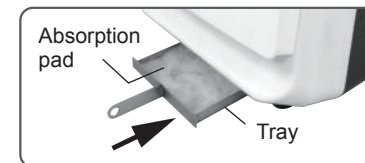

(5) Spray Cans

1. Open the side door.

Press the PUSH sign indicated in the photo to open the door.

■ Note

Do not use Acidity Cleaner which is used for air bearing handpieces only. It could damage both the TTcare 100+ and the handpiece.



2. Ensure the lock lever is on the left, place the spray can on the stand shown in the photo.

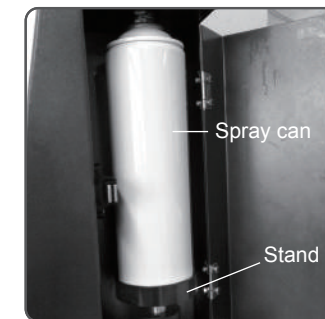

3. Shift the lock lever to the right to secure the spray can.

■ Note

Ensure the nozzle is properly connected. Make sure the lock lever is all the way to the right, otherwise the oil will not come out. Gently pull the spray can to ensure it is secured.

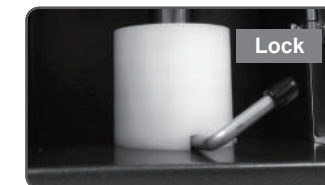

! NOTE

Oil will leak or disperse if the cans are not properly installed.

4. Gently lift the spray can and ensure the nozzle is secured.

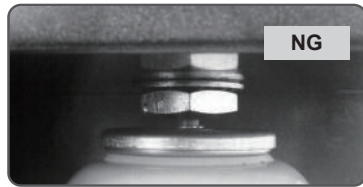
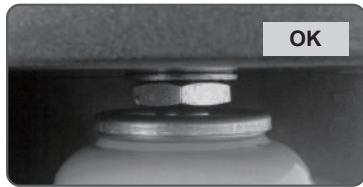

5. Use a hex wrench to adjust the screw on the spray can stand, if necessary.

■ **Note**

This can make up for a difference in height of 5mm.

NOTE

- It is recommended to use TT BIO or TTlube spray can for the TTcare 100+.
- The spray can nozzle and spray can stand are designed to offer compatibility with other spray can brands but do not mean all applicable.



6. Close the side door.

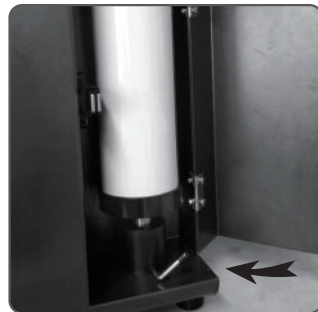

5. Operation

■ **Panel display:**

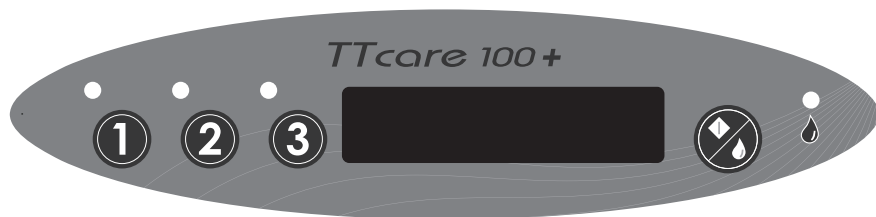

■ **Operating instruction:**

Icons	Functions	Illustration	
	Power On/Off		OFF
			ON
	Selection of handpiece 1	Handpiece 1 is selected when the lamp lights up.	
	Selection of handpiece 2	Handpiece 2 is selected when the lamp lights up.	
	Selection of handpiece 3	Handpiece 3 is selected when the lamp lights up.	
	Start / Set / Chuck maintenance switch	1. Handpiece maintenance when door is closed 2. Chuck maintenance when door is open 3. Function setting by long press and wait for the beep	
	Spray can change	Replace spray can when lamp lights up	

■ **Operating instruction:**

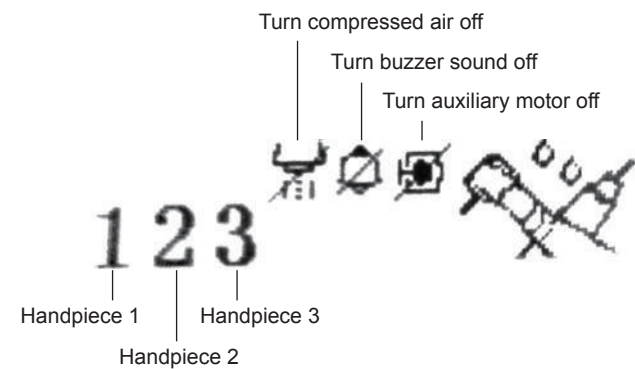

■ Operation maintenance:

■ Note

- Air Turbine and Contra Angle :
Remove the test bur from the handpiece.
- Straight Handpiece :
Insert the supplied test bur into the handpiece and locking.

(1) Chuck maintenance:

Turn on the power switch. Open the front door.

 will show on LCD Display during process.

Place the chuck side of head to the chuck nozzle.

Press  to begin cleaning and lubricating the chuck .

A beep sound meaning the procedure is completed.

(2) Handpiece maintenance:

Turn on the power switch.



Open the front door.

Connect the handpiece to its coupling with the chuck facing back.

Make sure the handpieces are connected to the adapter until it clicks into place.

Close the front door.

 will show on LCD Display during process.

Press  /  /  to select handpieces which are connected.

Press  to lubricate the handpieces in sequence order.

A beep sound meaning the procedure is completed.

■ Note



Pressing any button or opening the front door will immediately stop the maintenance procedure.

■ Functional setting:



Select functional setting mode by pressing  for approx 2 sec.

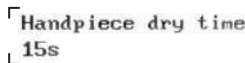

(1)  will show on LCD Display meaning compressed air is on.

Turn compressed air On/Off by pressing .



(2)  will show on LCD Display by pressing  shortly.

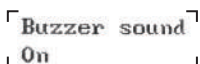



Maintenance time setting:

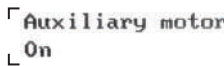

Select 15 sec by pressing  / Select 20 sec by pressing  / Select 30 sec by pressing .

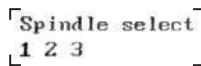
(3)  will show on LCD Display meaning buzzer sound is on by pressing  shortly.

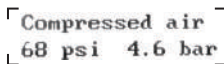

Select buzzer sound On/Off by pressing .

(4)  will show on LCD Display meaning auxiliary motor is on by pressing  shortly. Select Auxiliary motor On/Off by pressing .





(5)  will show on LCD Display by pressing  shortly. Press  /  /  to select handpieces which are connected to run optional auxiliary rotation.

(6)  will show on LCD Display by pressing  shortly.



■ Compressed air setting:

Adjust air pressure by turning  between 4.0-6.0 bars. Recommend to set air pressure at 4.0bars for TTcare 100+. Save and leave functional setting mode by pressing  shortly.

■ Oil amount adjustment :

(1) Indicator lights    and  are on when the Lubrication Unit is turned on. Press  for three seconds until it enters Oil amount adjustment mode, LCD will display:



(2) There are 11 adjustable oil amount from PU-00 to PU-10. Press  for increasing or  for decreasing. PU-00 is the default setting, PU-10 has the largest oil amount.

Choose the PU value required, press  button to complete setup. Lubrication unit will automatically reboot after setting adjustments.

6. Maintenance and Replacement Parts

■ Replace Fuse

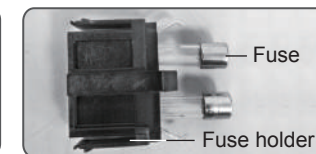

- (1) Press fuse holder by slotted wrench to loose the holder.
- (2) Remove fuse holder.
- (3) Replace new fuse (250V2A Slow-Blow type) into fuse holder
- (4) Insert fuse holder.

■ Remove and Clean Blister



⚠ WARNING

- The blister can be cleaned with 30°C±5°C tap water or 60% to 70% alcohol, non-high-temperature cleaning.
- The blister can be used repeatedly, but should be changed once broken.

■ Remove and Clean Front Door:

- (1) Push left pivot upward and inward.
- (2) Push right pivot upward and inward.

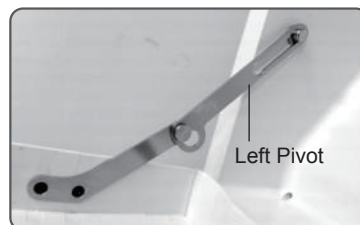

- (3) Pull front pin in the direction of arrow shown in the photo.
- (4) Remove front door.

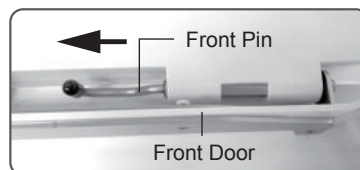

The front door can be cleaned with 30 ° ± 5 ° C tap water or 60% to 70% alcohol, non-high-temperature cleaning.



■ Cleaning the Tray:



- (1) Take the tray out in the direction of arrow shown in the photo.
- (2) Clean and replace new absorption pad.

⚠ CAUTION

- The tray cannot be autoclaved.
- Autoclaving will cause it to rust.
- Do not use disinfectants that contain chlorine-based cleaners or benzalkonium chloride or chlorinated aromatics.
- If this tray is not cleaned, oil will overflow from the tray.

! NOTE

- Dispose of used absorption pad according to regulations for medical waste.
- Push the tray all the way in, otherwise, oil may leak and oil mist might be dispersed.

■ Cleaning Couplings :

Loosen the nut and take the coupling off.

■ Note

- (1) Remove it carefully without damaging the o-ring.
- (2) Couplings cannot be autoclaved.

Clean it with ethanol 60 to 70 vol%

An o-ring could slip out of its groove. Make sure all o-rings are properly seated in their grooves before attaching a handpiece.

■ Note

Do not connect handpiece to the coupling when o-ring is not properly fitted in its groove. Possible damages to the o-ring and stuck in the coupling may make it difficult for disassembling handpiece.

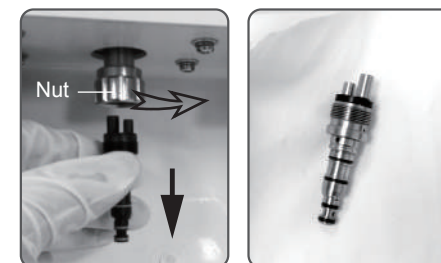

7. Maintenance and Inspection

* Send the product every 2 years for a service check.

The safety checks in different countries can vary in compliance with country specific regulations and requirements for medical devices. The national valid regulations are to be observed.

* Repair and maintenance work- part from the activities described in these operating instructions-may be performed only by qualified technical staff.

* Expected service life 5 years.

• In the event of modification by third parties, existing medical device licences become null and void.

• Only use original parts and spare parts.

• The user(i.e. clinic, hospital etc.) is responsible for the management, maintenance and use of medical devices.

■ Regular Inspection

* Maintenance and inspection are generally considered to be the duty and obligation of the user, but if, for some reason, the user is unable to carry out these duties, they may rely on a qualified medical device serviceman. Contact your local dealer or the TTIBO CORP. for details.

- (1) Power Supply Cord
Inspect visually for wear and broken wires.
- (2) Main and Operation Switches
Turn on main switch and ensure main lamp lights up.
Check that the unit operates correctly.
- (3) Absorption pads
Replace absorption pads(when the tray is filled by oil)..

• Regularly Required Replacement Parts

Fuse

• Other Replacement Parts

Absorption pads, Blister

8. Trouble Shooting and Error Code



■ Trouble Shooting

Breakdown	Reason	Solution
Main power lamp does not light up	Power supply cord not properly plugged into supply socket	Plug in properly
	Power supply cord not properly plugged into TTcare100+	
Does not start when Start Switch is pressed. (1) Double beep sound (2) Spray can Empty Lamp is blinking	Front door may be open	Close front door
	Empty can	Replace can
	Can is not properly installed	Properly install the can
	Compressor air is not connected	Connect air
Unusual odor. Surfaces are unusually dirty.	Air regulator is not set properly	Set regulator properly
	Use without connecting handpiece	Select only couplings that have a handpiece connected
	Absorption pads is saturated	Clean TTcare100+ and replace filter
	Can is not properly installed	Properly install the can
Cannot install spray can. Oil leaks from spray can.	Air regulator is not set properly	Set regulator properly
	Bent spray can nozzle pin	Replace can
Oil mist is released. Equipment surfaces get oily	Wrong stand for spray can	Use proper stand for can
	Type of handpiece or coupling	Depending on the type of handpiece and coupling, there could be a release of oil mist. In this case, lower the pressure to 4 bar
	Air pressure too high	Reduce air pressure, but not less than 4 bar
	No burr inserted in straight attachment.	Refer to the user instructions for the handpiece. For some handpieces, an oil mist may be released if a burr is not inserted

■ Error Code

Error Code	Description	Reason	Exclusion
Error 01	Keyboard Error	Function keypad Error	Contact your dealer
Error 02	Oil supply motor Error	Faulty Motor or internal circuit	Contact your dealer
Error 03	Auxiliary rotation motor Error	Faulty Motor or internal circuit	Contact your dealer
Error 04	Pressure input too low	Air pressure lower than preset	Increase air pressure renew air setting(refer to chapter 4)
Error 05	Pressure input too high	Air pressure higher than preset	Decrease air pressure renew air setting(refer to chapter 4)
Error 06	Function Memory Access Error	Faulty Main IC	Contact your dealer
Error 07	Oil empty	Oil empty	Replace a new can of oil or Contact your dealer
Error 08	Electromagnetic valve Error	Faulty Electromagnetic valve	Contact your dealer
Error 09	Circuit is over temperature	Faulty Motor or internal circuit	Contact your dealer
Error 10	Circuit detect Error	Faulty Main IC	Contact your dealer

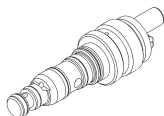
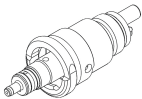
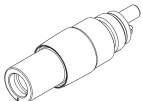
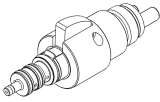
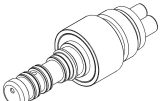
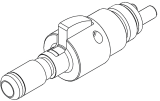
9. Tools and consumables

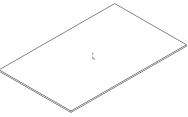
Presentation	Material summary	Part No.
	KaVo service adapter	0PL0345
	W&H service adapter	0PL0346
	NSK service adapter	0PL0344
	Bien-Air service adapter	0PL0348
	SIRONA service adapter	0PL0347
	E-Type adapter	0PL0349
	Spray can	08090011
	Blister	0PL0350
	Absorption pads	0PL0351

10. Service Contacts

■ **For repair or other types of service contact your local dealer or TT BIO CORP.**

■ Disposal of Medical Devices

Any medical devices which could possibly be contaminated must be first decontaminated by the responsible doctor or medical institution and then be disposed by an agent licensed and qualified to handle medical and industrial waste.

11. Information on Electromagnetic Compatibility

Guidance and manufacturer's declaration-electromagnetic emissions		
The TTcare 100+ is intended for use in the electromagnetic environment specified below. The customer or the user of the TTcare 100+ should assure that it is used in such an environment.		
Emission Test	Compliance	Electromagnetic environment-guidance
RF emissions CISPR 11	Group 1	The TTcare 100+ uses RF energy only for its internal function. Therefore, its RF emissions are very low and are not likely to cause any interference in nearby electronic equipment.
RF emissions CISPR 11	Group B	The TTcare 100+ is suitable for use in all establishments, including domestic establishments and those directly connected to the public low-voltage power supply network that supplies buildings used for domestic purposes.
Harmonic emissions IEC 61000-3-2	Group A	
Voltage fluctuations /flicker emissions IEC 61000-3-3	Compliance	

Guidance and manufacturer's declaration-electromagnetic immunity			
The TTcare 100+ is intended for use in the electromagnetic environment specified below. The customer or the user of the TTcare 100+ should assure that it is used in such an environment.			
Immunity test	IEC 60601 test level	Compliance level	Electromagnetic environment-guidance
Electrostatic discharge(ESD) IEC 61000-4-2	± 6 kV contact ± 8 kV air	± 6 kV contact ± 8 kV air	Floors should be wood, concrete or eramic tile. If floors are covered with synthetic material, the relative humidity should be at least 30%
Electrical fast transient/burst IEC 61000-4-4	± 2kV for power supply lines ± 1kV for input/output lines	± 2kV for power supply lines Not applicable	Mains power quality should be that of a typical commercial or hospital environment.
Surge IEC 61000-4-5	± 1kV line(s) to line(s) ± 2kV line(s) to earth	± 1kV differential mode Not applicable	Mains power quality should be that of a typical commercial or hospital environment.
Voltage Dips, short interruptions and voltage variations on power supply input lines IEC 61000-4-11	<5% UT(>95% dip in UT) for 0,5 cycle 40% UT(60% dip in UT) for 5 cycles 70% UT(30% dip in UT) for 25 cycles <5% UT(>95% dip in UT) for 5 s	<5% UT(>95% dip in UT) for 0,5 cycle 40% UT(60% dip in UT) for 5 cycles 70% UT(30% dip in UT) for 25 cycles <5% UT(>95% dip in UT) for 5 s	Mains power quality should be that of a typical commercial or hospital environment. If the user of the TTcare 100+ requires continued operation during power mains interruptions, it is recommended that the TTcare 100+ be powered from an uninterruptible power supply or a battery.
Power frequency (50/60 Hz) magnetic field IEC 61000-4-8	3 A/m	3 A/m	The TTcare 100+ power frequency magnetic fields should be at levels characteristic of a typical location in a typical commercial or hospital environment.
<p>■ Note: UT is the a.c. mains voltage prior to application of the test level.</p>			

Guidance and manufacturer's declaration-electromagnetic immunity			
The TTcare 100+ is intended for use in the electromagnetic environment specified below. The customer or the user of the TTcare 100+ should assure that is used in such and environment.			
Immunity test	IEC 60601 test level	Compliance level	Electromagnetic environment-guidance
Conducted RF IEC 61000-4-6	3 Vrms 150 KHz to 80 MHz	3 Vrms	<p>Portable and mobile RF communications equipment should be used no closer to any part of the TTcare 100+ including cables, than the recommended separation distance calculated from the equation applicable to the frequency of the transmitter.</p> <p>Recommended separation distance: $d = 1,2 \sqrt{P}$ $d = 1,2 \sqrt{P}$ 80MHz to 800 MHz $d = 2,3 \sqrt{P}$ 800MHz to 2,5 GHz</p> <p>Where P is the maximum output power rating of the transmitter in watts (W) according to the transmitter manufacturer and d is the recommended separation distance in metres (m).</p> <p>Field strengths from fixed RF transmitters, as determined by an electromagnetic site survey, ^a should be less than the compliance level in each frequency range.^b</p> <p>Interference may occur in the vicinity of equipment marked with the following symbol:</p> 
Radiated RF IEC 61000-4-3	3 V/m 80MHz to 2,5 GHz	3 V/m	
<p>■ Note1: At 80 MHz and 800 MHz, the higher frequency range applies.</p> <p>■ Note2: These guidelines may not apply in all situations. Electromagnetic propagation is affected by absorption and reflection from structures, objects and people.</p>			
<p>■ a: Field strengths from fixed transmitters, such as base stations for radio (cellular/cordless) telephones and land mobile radios, amateur radio, AM and FM radio broadcast and TV broadcast cannot be predicted theoretically with accuracy. To assess the electromagnetic environment due to fixed RF transmitters, an electromagnetic site survey should be considered. If the measured field strength in the location in which the TTcare 100+ is used exceeds the applicable RF compliance level above, the TTcare 100+ should be observed to verify normal operation. If abnormal performance is observed, additional measures may be necessary, such as re-orienting or relocating the TTcare 100+.</p> <p>■ b: Over the frequency range 150 kHz to 80 MHz, field strengths should be less than 3 V/m.</p>			



Recommended separation distance between portable and mobile RF communications equipment and the TTcare 100+			
The TTcare 100+ is intended for use in an electromagnetic environment in which radiated RF disturbances are controlled. The customer or the user of the TTcare 100+ can help prevent electromagnetic interference by maintaining a minimum distance between portable and mobile RF communications equipment (transmitters) and the TTcare 100+ as recommended below, according to the maximum output power of the communications equipment.			
Rated maximum output power of transmitter W	Separation distance according to frequency of transmitter M		
	150 kHz to 80 MHz d = 1,2√P	80 MHz to 800 MHz d = 1,2√P	800 MHz to 2,5 GHz d = 2,3√P
0.01	0.02	0.12	0.23
0.1	0.38	0.38	0.73
1	1.2	1.2	2.3
10	3.8	3.8	7.3
100	12	12	23
For transmitters rated at a maximum output power not listed above, the recommended separation distance d in metres (m) can be estimated using the equation applicable to the frequency of the transmitter, where p is the maximum output power rating of the transmitter in watts (W) according to the transmitter manufacturer.			
<p>■ Note1: At 80 MHz and 800 MHz, the separation distance for the higher frequency range applies.</p> <p>■ Note2: These guidelines may not apply in all situations. Electromagnetic propagation is affected by absorption and reflection from structures, objects and people.</p>			

注意事項	25
免責聲明	26
1. 警告，注意和提醒	26
2. 規格	27
3. 零件說明	30
4. 設定	32
5. 操作	34
6. 維修和更換零件	37
7. 保養和檢查	40
8. 異常排除和故障碼	41
9. 工具和消耗品	43
10. 服務聯繫	44
11. 電磁相容性資訊	45

注意事項

大多數操作和維護問題都是因為忽略最基本的安全預防措施，並且沒有能夠預見到事故的問題和事故的可能性。要避免問題產生與危險的可能性請按照製造商的建議操作。首先仔細閱讀所有有關安全和事故預防和注意事項；然後在操作上需謹慎，以防止設備損壞或造成人身傷害。

注意下列符號和用語的含義：

	警告	嚴重受傷或設備損壞或故障或引起火災的危險
	注意	使用不適當的方法或工具來操作設備
	提醒	設備損壞或中等傷害

■ **提醒：**

此提醒用戶相關的操作要點。

用戶（即診所，醫院等）負責管理，維護和使用此保養設備。除非具有專業資格的牙醫或護士，其餘人都不適合操作此設備。

切勿把此設備用於非預期用途。

■ **注意：**

美國聯邦法律規定，此設備只能出售於有合格專業證書的牙醫。

注意

TTBIO對於從事下面事項而造成設備損壞，將不負責任

- (1) 由未經TTBIO授權的人員進行維修。
- (2) 任何變更，修改或改變此產品。
- (3) 維護或修理使用非TTBIO生產的零件或部件，而導致原始設定條件失效。
- (4) 使用非此手冊提到的操作程序或沒有遵守本手冊中提到安全注意事項和警告。
- (5) 工作場所的條件和環境，或安裝條件不符合本手冊中所規定的條件。
- (6) 火災，地震，洪水，雷電，自然災害，或不可抗力之因素。

1. 警告，注意和提醒

警告

- 爆炸危害。使用時不要靠近火源或其他點火源。
- 健康危害。通風必須保持良好。因為吸入過多的煙霧可能會損害您的健康。
- 設備電源必須正確的連接。
- 電源接地需正確且妥善的連接與建立。
- 為了防止危及生命的疾病或病菌蔓延，如愛滋病和B型肝炎，在使用TTcare100+後，牙科手機需進行高溫滅菌消毒。
- 避免觸電的風險。設備損壞和火災與雷電期間：關閉TTcare100+電源，且不要觸摸它或電源線。
- 操作或清潔TTcare100+時，請戴上手套，口罩和防護眼鏡。

注意

手機，收發器，遙控器和類似的裝置有可能會引起電磁波干擾，造成設備錯誤。在靠近工作區會發射電磁波的相關裝置都必須被關閉。

提醒

- 不同的牙科手機和快速接頭，所釋放的油霧會不一樣。減少油霧的產生可調降壓力為最低的設定值4bar。
- 保養油罐安裝不正確，會導致保養油洩漏或是無法順利出油。
- 筒夾保養時需確定牙科手機的筒夾有對準噴嘴。如果傾斜，會導致保養油噴射出來。
- 在保養未完成（蜂鳴聲）前，就把牙科手機從接頭拆下，會導致保養油從接頭噴射而出。

- 對於某些牙科手機，在鑽針沒有安裝的情況下，油霧可能會被散出。
- 將牙科手機安裝到設備的接頭時，請不要損壞上面的O型環。這會導致保養油洩漏而使保養效果不佳。
- 不要選擇一個跟手機不相配的快速接頭，這會導致在按下啟動開關後保養油洩出。
- 如果一段時間不使用此設備，請將連接此設備，診所內的主空氣閥關閉。
- 請確認您使用正確的電源供應於TTcare100+。
- 不要使用非TTBIO生產的快速接頭於TTcare100+，這可能會導致釋放油霧過多 或牙科手機保養不佳。
- 根據當地醫療廢棄物法規處置用過的吸油墊。
- 請將集油盤完全推入，否則過多的油與油霧可能洩漏。

2. 規格

產品名稱	TTcare 100+
電壓與頻率	AC 100-240 V 50/60 Hz
電力消耗	60VA max.
保險絲	250V 2A Slow Blow Type
壓力需求	4~6 bar
建議壓力	4 bar
空氣流量	40 NL/ min
重量	9 kg
尺寸（寬 / 高 / 深）	295 ×385 ×295 mm
保護等級（防塵防水）	IP20

工作環境要求

位置	只允許在室內使用
環境溫度	15 to 40°C (59 to 104°F)
相對溼度	25 to 90 %
最大海拔高度	2000 m (6560 feet)

儲存及運輸環境

環境溫度	-20 to 70°C (-4 to 158°F)
相對溼度	5 to 95 %
大氣壓力	700 to 1060 hPa

■ 產品說明

用於保持牙科手機最佳性能和延長工作壽命。
自動提供保養油和空氣於潤滑清潔牙科手機。
用於牙科治療後，滅菌前。

■ 廢棄物處置

廢棄物必須在不傷害人類和環境的方法下回收處理；請遵照當地國家的法規進行。

到了壽命使用期限時，設備和配件的處置：

根據2002/96/EC的廢電氣電子設備指令，指出本產品標籤目前遵守其規定，但未受限於此指令處置要求，然而，本產品可能由歐洲特殊廢棄物管理中心處理，其他的資訊可透過製造商或牙科供應商取得。

■ 符號的意義

• 設備標籤

TTBIO **TTcare 100+**
Automatic Handpiece Maintenance Unit
TTBIO CORP.
2F, No.7, 6th Road Industry Park Taichung, Taiwan 40755
Product code : 08090012XXX
SN XXXXXXXXXXXXX

INPUT :AC 100~240V 50/60 Hz
60VA max.
AIR PRESSURE: 4~6 bar
FUSE: 250V 2A Slow Blow Type

CE, IP20, and other safety icons.



WARNING

- The blister can be cleaned with 30°C±5°C tap water or 60% to 70% alcohol, non-high-temperature cleaning.
- The blister can be used repeatedly, but should be changed once broken.

FLAMMABLE

- Spray cans will explode if they get too hot.
- Do not expose the spray cans to heat.
- Only use approved spray can.

*** PREVENT EXPLOSION AND IGNITION OF SPRAY CANS!**

• 設備上的符號

	注意操作手冊	SN	產品序號
	生產日期		注意
	廢棄資訊 參照重要資訊” 廢棄物處置”		易燃

IP20	保護等級（防塵防水）		護目鏡佩戴
-------------	------------	--	-------

• 外箱標籤

TTBIO **TTcare 100+**
Automatic Handpiece Maintenance Unit
TTBIO CORP.
2F, No.7, 6th Road Industry Park Taichung, Taiwan 40755
Product Code:08090012 SN XXXXXXXXXXXXX

Storage and transport requirements

Temperature range: -20°C to 70°C
Air Pressure: 700 hPa to 1060 hPa
Humidity: 5% to 95%

Transport upright, Fragile, Stacking restriction (20 kg), Keep dry, Waste Disposal.

• 包裝上的符號

	易碎		氣壓
	保持乾燥		溼度
	垂直運輸		數量
	疊放規定		製造商
	溫度範圍		

■ 主電源開關

	關		開
--	---	--	---

3. 零件說明

■ 介紹

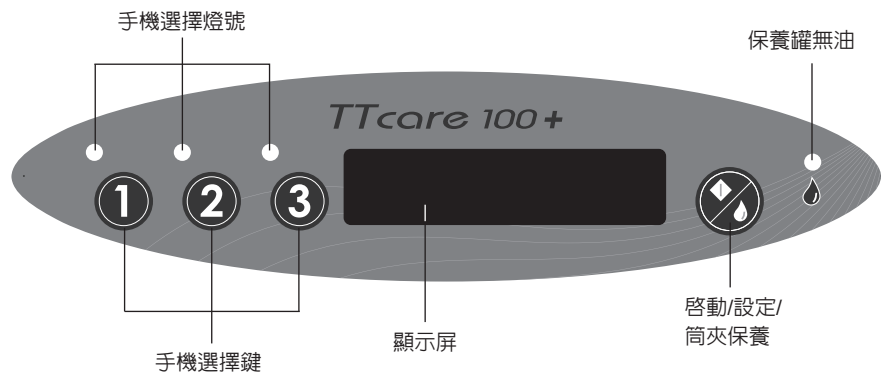
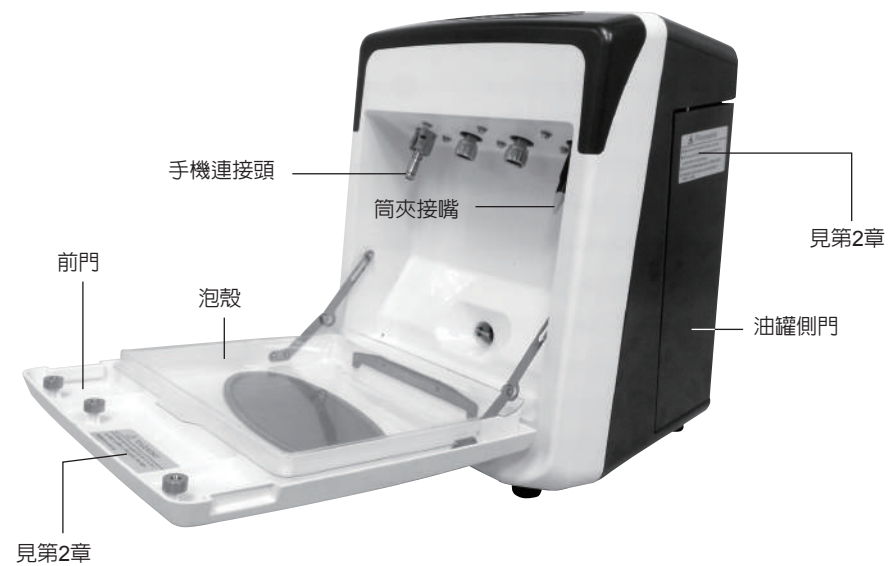

■ 內容物

<p>保養機</p>	<p>泡殼 料號：OPL0350</p>	<p>吸油棉 料號：OPL0351</p>
<p>集油盤 料號：OPL0359</p>	<p>氣壓管 料號：OPL0360</p>	

* TTcare 100+ 包含上述標準配備。

* 選購配件，請參閱第9章。

4. 設定

■ 注意

TTcare100 + 安置至少要離牆面5公分（2英吋）的距離，不可緊貼牆面。

(1) 氣壓連接

1. 將氣壓管連接到氣壓連接孔。打開診所內的供氣閥。

■ 注意

供給的氣必須是清潔不含油的。
請確保牢固地連接氣壓管。



2. 調整氣壓調整閥，將氣源設定4~6 bar。推薦的氣壓為4 bar。

■ 注意

氣壓小於4bar或高於6 bar將會發生錯誤，會產生錯誤代碼並顯示於顯示屏。

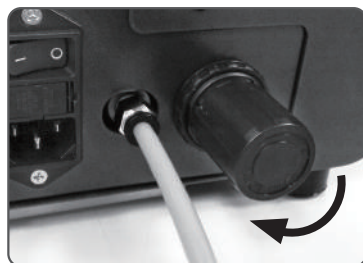

(2) 電源連接

將電源線的一端插入主機，另一端插入電源插座。



■ 注意

確保螺帽是有旋緊的。否則，油和空氣會洩漏，而導致保養不完全。



(4) 集油盤

放入兩個吸油墊並往後推到底。

■ 注意

集油盤需正確放入，否則，它會導致洩漏。

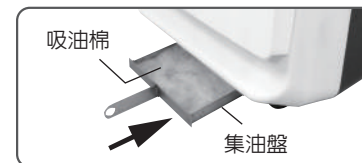

(5) 噴罐

1. 打開油罐側門。

按下PUSH標誌，如右圖所示。

■ 注意

不要使用含有酸性或鹼性的清潔劑，它會損壞TTcare100+和牙科手機。



2. 確定如左圖中所示的固定桿，它是往左邊的，然後放入保養油罐。

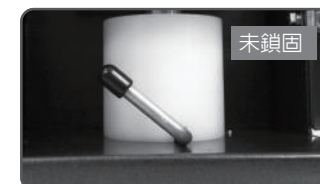

3. 將固定桿往右邊推，使得油罐被固定，如右圖所示。

■ 注意

確定油罐噴嘴與保養罐是對正的。
確定固定桿如右圖所示，是往右的，否則油會出不來。
可輕輕拉一拉噴霧罐，確定它是穩固不會晃動的。

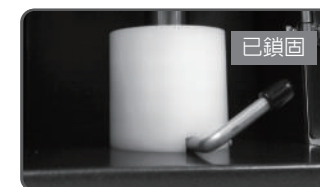
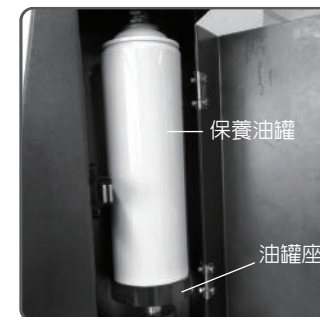

! 注意

若是油罐沒被正確的安裝，它將會造成洩漏。

4. 輕輕抬起噴霧罐，確認油罐噴嘴是否被固定，如下圖所示。

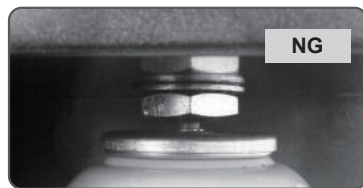
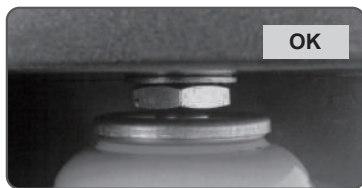

5. 如果油罐是鬆動的，可使用六角板手調整如右圖所示的螺絲。

■ 注意

可調整的高度距離約5mm。

注意

- 建議使用TTBIO生產的 TTlube保養罐。
- 油罐噴嘴和油罐座的設計可相容於某些品牌的保養油罐，但不代表所有的保養油罐都可用。



6. 關上油罐側門。

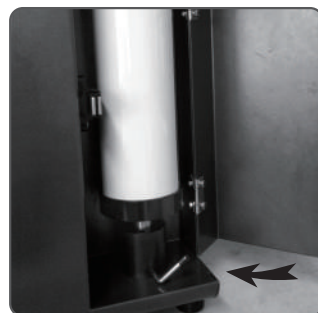

5. 操作

■ 面板顯示

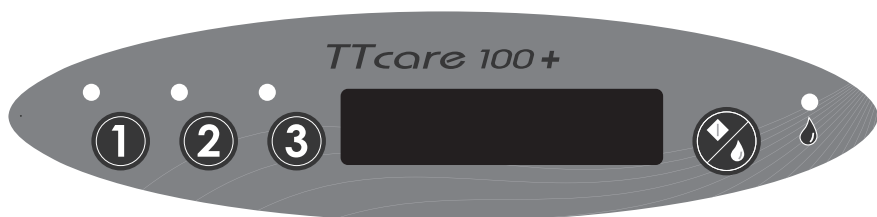

■ 操作指令

圖示	功能	操作指令	
	電源開關		關
			開
	1號手機	當選擇1號時燈會亮起	
	2號手機	當選擇2號時燈會亮起	
	3號手機	當選擇3號時燈會亮起	
	開始 / 設定 / 筒夾保養	1.門關閉時，進行牙科手機保養 2.門打開時，進行筒夾保養 3.無任何燈號亮起時，長按進入功能設定	
	保養油耗盡	當燈號亮起代表油罐無油請更換	

■ 操作顯示說明

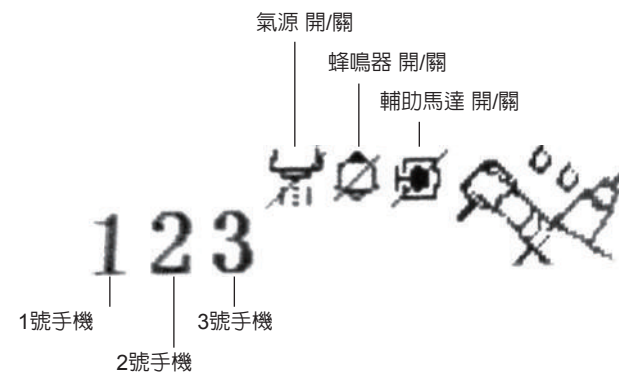

■ 保養操作

■ 注意

- 高速手機與彎手機
保養時移除手機上的鑽針
- 直手機
保養時手機上插入鑽針並鎖上

(1) 筒夾保養：

打開電源，打開前門。



此符號將會顯示於顯示屏上。

將筒夾對準於設備噴嘴的出口。

按下  進行保養，發出“嗶”聲代表完成保養。

(2) 手機保養：

打開電源，打開前門。

將手機連接到設備的保養接頭上，請確認連接是有牢固的。

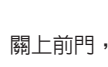

此符號將會顯示於顯示屏上。

選擇有接手機的位置，並按下  /  /  進行保養，

 發出“嗶”聲代表完成保養。

■ 注意

保養過程中，按下任意鍵或打開前門，保養將馬上停止。

■ 功能設定：

長按  鍵約2秒，進入設定功能。

- (1)  氣源輸入 ON/OFF，按下  可做切換。
- (2)  保養吹氣時間，：15秒，：20秒，：30秒。
- (3)  蜂鳴器響聲ON/OFF，按下  可做切換。
- (4)  輔助馬達 ON/OFF，按下  可做切換。

- (5)  輔助馬達運轉選擇，按下  /  /  來各別選擇需要啟動的手機。
- (6)  氣源輸入顯示，按下  確定。

■ 氣源輸入調整：



拉起壓力調整閥  然後轉動，調整壓力在4.0~6.0 bars。建議壓力為4.0 bars。

按下  鍵確定。

■ 保養油量調整：

(1) 開機後，在    和  的指示燈號一起全亮時，按下  鍵，

直到螢幕出現 。

(2) 總共有PU-00到PU-10共11段油量可供調整。按下  為增加，按下  為減少，選擇你所需的油量後，按下  鍵確定儲存便會自動回到主畫面。

6. 保養和更換零件

■ 更換保險絲

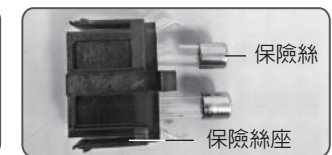

- (1) 使用一字起子壓住保險絲座。
- (2) 拉起保險絲座。
- (3) 更換保險絲 (規格：250V 2A Slow-Blow type)
- (4) 將更換完畢的保險絲座插回。

■ 移除和清潔泡殼



往上拉即可移除

警告

- 此泡殼僅能用30°C±5°C的自來水清洗，或是60~70%的酒精擦拭，不能高溫清洗。
- 此泡殼能反覆使用，但若有破損請更換，否則會導致保養油洩露出。

■ 移除和清潔前門

- (1) 往上拉起左邊門樞再往內靠。
- (2) 往上拉起右邊門樞再往內靠。

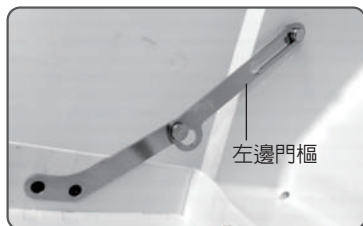

左邊門樞

- (3) 將前門拉桿往右圖所示的方向拉。
- (4) 便可移除前門。

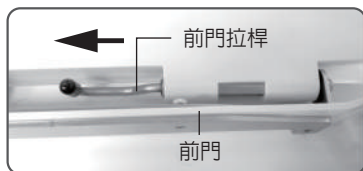

前門拉桿

前門

此前門僅能用30°C±5°C的自來水清洗，或是60~70%的酒精擦拭，不能高溫清洗。



■ 清潔油盤



- (1) 將油盤往上圖所示的方向拉出。
- (2) 清潔和更換新的吸油棉。

注意

- 此油盤不能高壓滅菌。
- 高壓滅菌會導致生鏽。
- 切勿使用含氯清潔劑或氯化消毒劑擦拭清洗。
- 如果沒有清理油盤，將會導致保養油洩露出。

提醒

- 使用過的吸油棉需根據當地醫療廢棄物相關法規處理與回收。
- 油盤需往內推到底，否則保養油會洩露出。

■ 清潔快速接頭

旋開螺帽後往下拉移除，如右圖所示。

■ 提醒

- (1) 移除時請小心不要損壞到O型環。
- (2) 快速接頭不能高壓滅菌。

可使用60~70%的酒精擦拭。

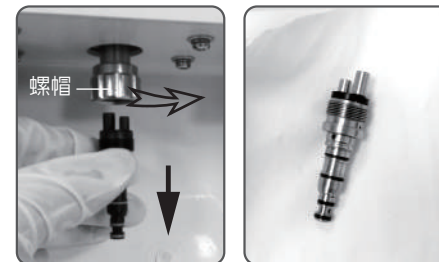

O型環可以從溝槽中被拉出來。

在插入手機前，請確認所有的O型環是有被固定在在凹槽的。

■ 提醒

當O型環沒被正確安裝在溝槽時，請不要連接手機，這可能導致O型環會卡在手機內部，以致於手機難以卸除。



7. 保養和檢查

* 每2年將產品送回檢查。

安全檢查會依據各國醫療裝置法規而不同。可遵照國家法規進行。

* 維修及保養工作，可參照書中所描述的方法來執行，但只可以由合格的技術人員進行。

* 預計使用壽命5年。

- 在透過第三方修改的情況下，現有的醫療器械許可證將會變得無效。
- 只能使用原廠配件和維修備件。
- 使用者（如：診所，醫院等）負責此設備的管理，維護和使用。

■ 定期檢查

* 維護和檢查通常被認為是使用者的責任和義務，但如果由於某種原因，用戶無法執行這些工作，可委託合格的醫療器械維修人員。請聯繫您當地的經銷商或TTIBO股份有限公司。如下詳細資料。

(1) 電源線

目視檢查是否有磨損和斷線。

(2) 主要操作開關

打開主開關，並確定電源燈有亮起。

確認設備主機可以正常運行工作。

(3) 吸油棉

更換吸油棉（當油盤充滿油時）。

- 須定期更換零件
保險絲
- 其它更換零配件
吸油棉，泡殼

8. 異常排除與故障碼

■ 異常排除

故障	原因	排除方式
主電源燈不亮	電源線沒有插入電源插座	正確安裝電源線
	電源線沒有插入TTcare 100+	
按下開始鍵無法啟動 (1) 發出響聲 (2) 保養罐無油	前門被開啓	關閉前門
	空油罐	更換油罐
	油罐未正確安裝	正確安裝油罐
	氣源沒有連接	連接氣源
不尋常的氣味 表面異常髒污	氣源沒有正確設定	正確設定氣源
	沒有連接手機	連接手機
	吸油棉已飽和	清潔TTcare 100+和更換吸油棉
	油罐未正確安裝	正確安裝油罐
未安裝油罐 油從油罐溢出	氣源沒有正確設定	正確設定氣源
	油罐的噴嘴彎曲	更換油罐
	錯誤的油罐座	使用正確的油罐座
油洩漏出 設備表面都是油	手機或接頭類型	某些手機和接頭類型，有可能會導致油霧釋放過多。在這種情況下，請降低壓力為4bar
	氣源過高	設定氣源但不低於4 bar
	無鑽針插入	請參照手機的用戶指令。對於某些牙科手機，如果未插入鑽針會導致油霧散出。

■ 故障碼

錯誤碼	說明	原因	排除方式
Error 01	按鍵錯誤	功能鍵故障	請與經銷商聯繫
Error 02	供油馬達錯誤	馬達損壞或內部電流錯誤	請與經銷商聯繫
Error 03	輔助馬達錯誤	馬達損壞或內部電流錯誤	請與經銷商聯繫
Error 04	氣壓過低	氣源壓力設定過低	調整增加氣源 (設定請見第4章)
Error 05	氣壓過高	氣源壓力設定過高	調整減少氣源 (設定請見第4章)
Error 06	功能記憶錯誤	電子IC損壞	請與經銷商聯繫
Error 07	無油	空油罐	更換新油罐 請與經銷商聯繫
Error 08	電磁閥錯誤	電磁閥故障	請與經銷商聯繫
Error 09	電流過高	馬達損壞或內部電流錯誤	請與經銷商聯繫
Error 10	電流偵測錯誤	電子IC損壞	請與經銷商聯繫

9. 工具和消耗品

圖示	說明	料號
	保養接頭 KaVo	0PL0345
	保養接頭 W&H	0PL0346
	保養接頭 NSK	0PL0344
	保養接頭 Bien-Air	0PL0348
	保養接頭 SIRONA	0PL0347
	保養接頭 E-Type	0PL0349
	TTlube 保養油罐	08090011
	泡殼	0PL0350
	吸油棉	0PL0351

10. 服務聯繫

■ 對於維修或其他類型的服務，請聯繫您當地的經銷商或TTBIO CORP。

■ 醫療設備的處置

任何被污染的醫療設備都必須先由負責的醫生或醫療機構先清洗，再交於有合格處理醫療廢棄物和工業廢棄物的機構。

11. 電磁相容性資訊

Guidance and manufacturer's declaration-electromagnetic emissions

The TTcare 100+ is intended for use in the electromagnetic environment specified below.
The customer or the user of the TTcare 100+ should assure that it is used in such an environment.

Emission Test	Compliance	Electromagnetic environment-guidance
RF emissions CISPR 11	Group 1	The TTcare 100+ uses RF energy only for its internal function. Therefore, its RF emissions are very low and are not likely to cause any interference in nearby electronic equipment.
RF emissions CISPR 11	Group B	The TTcare 100+ is suitable for use in all establishments, including domestic establishments and those directly connected to the public low-voltage power supply network that supplies buildings used for domestic purposes.
Harmonic emissions IEC 61000-3-2	Group A	
Voltage fluctuations /flicker emissions IEC 61000-3-3	Compliance	

Guidance and manufacturer's declaration-electromagnetic immunity			
The TTcare 100+ is intended for use in the electromagnetic environment specified below. The customer or the user of the TTcare 100+ should assure that it is used in such an environment.			
Immunity test	IEC 60601 test level	Compliance level	Electromagnetic environment-guidance
Electrostatic discharge(ESD) IEC 61000-4-2	± 6 kV contact ± 8 kV air	± 6 kV contact ± 8 kV air	Floors should be wood, concrete or eramic tile. If floors are covered with synthetic material, the relative humidity should be at least 30%
Electrical fast transient/burst IEC 61000-4-4	± 2kV for power supply lines ± 1kV for input/output lines	± 2kV for power supply lines Not applicable	Mains power quality should be that of a typical commercial or hospital environment.
Surge IEC 61000-4-5	± 1kV line(s) to line(s) ± 2kV line(s) to earth	± 1kV differential mode Not applicable	Mains power quality should be that of a typical commercial or hospital environment.
Voltage Dips, short interruptions and voltage variations on power supply input lines IEC 61000-4-11	<5% UT(>95% dip in UT) for 0,5 cycle 40% UT(60% dip in UT) for 5 cycles 70% UT(30% dip in UT) for 25 cycles <5% UT(>95% dip in UT) for 5 s	<5% UT(>95% dip in UT) for 0,5 cycle 40% UT(60% dip in UT) for 5 cycles 70% UT(30% dip in UT) for 25 cycles <5% UT(>95% dip in UT) for 5 s	Mains power quality should be that of a typical commercial or hospital environment. If the user of the TTcare 100+ requires continued operation during power mains interruptions, it is recommended that the TTcare 100+ be powered from an uninterruptible power supply or a battery.
Power frequency (50/60 Hz) magnetic field IEC 61000-4-8	3 A/m	3 A/m	The TTcare 100+ power frequency magnetic fields should be at levels characteristic of a typical location in a typical commercial or hospital environment.
<p>■ Note: UT is the a.c. mains voltage prior to application of the test level.</p>			

Guidance and manufacturer's declaration-electromagnetic immunity			
The TTcare 100+ is intended for use in the electromagnetic environment specified below. The customer or the user of the TTcare 100+ should assure that is used in such and environment.			
Immunity test	IEC 60601 test level	Compliance level	Electromagnetic environment-guidance
Conducted RF IEC 61000-4-6	3 Vrms 150 KHz to 80 MHz	3 Vrms	<p>Portable and mobile RF communications equipment should be used no closer to any part of the TTcare 100+ including cables, than the recommended separation distance calculated from the equation applicable to the frequency of the transmitter.</p> <p>Recommended separation distance: $d = 1,2 \sqrt{P}$ $d = 1,2 \sqrt{P}$ 80MHz to 800 MHz $d = 2,3 \sqrt{P}$ 800MHz to 2,5 GHz</p> <p>Where P is the maximum output power rating of the transmitter in watts (W) according to the transmitter manufacturer and d is the recommended separation distance in metres (m).</p> <p>Field strengths from fixed RF transmitters, as determined by an electromagnetic site survey, ^a should be less than the compliance level in each frequency range.^b</p> <p>Interference may occur in the vicinity of equipment marked with the following symbol:</p> 
Radiated RF IEC 61000-4-3	3 V/m 80MHz to 2,5 GHz	3 V/m	
<p>■ Note1: At 80 MHz and 800 MHz, the higher frequency range applies.</p> <p>■ Note2: These guidelines may not apply in all situations. Electromagnetic propagation is affected by absorption and reflection from structures, objects and people.</p>			
<p>■ a: Field strengths from fixed transmitters, such as base stations for radio (cellular/cordless) telephones and land mobile radios, amateur radio, AM and FM radio broadcast and TV broadcast cannot be predicted theoretically with accuracy. To assess the electromagnetic environment due to fixed RF transmitters, an electromagnetic site survey should be considered. If the measured field strength in the location in which the TTcare 100+ is used exceeds the applicable RF compliance level above, the TTcare 100+ should be observed to verify normal operation. If abnormal performance is observed, additional measures may be necessary, such as re-orienting or relocating the TTcare 100+.</p> <p>■ b: Over the frequency range 150 kHz to 80 MHz, field strengths should be less than 3 V/m.</p>			

Recommended separation distance between portable and mobile RF communications equipment and the TTcare 100+			
The TTcare 100+ is intended for use in an electromagnetic environment in which radiated RF disturbances are controlled. The customer or the user of the TTcare 100+ can help prevent electromagnetic interference by maintaining a minimum distance between portable and mobile RF communications equipment (transmitters) and the TTcare 100+ as recommended below, according to the maximum output power of the communications equipment.			
Rated maximum output power of transmitter W	Separation distance according to frequency of transmitter M		
	150 kHz to 80 MHz d = 1,2√P	80 MHz to 800 MHz d = 1,2√P	800 MHz to 2,5 GHz d = 2,3√P
0.01	0.02	0.12	0.23
0.1	0.38	0.38	0.73
1	1.2	1.2	2.3
10	3.8	3.8	7.3
100	12	12	23

For transmitters rated at a maximum output power not listed above, the recommended separation distance d in metres (m) can be estimated using the equation applicable to the frequency of the transmitter, where p is the maximum output power rating of the transmitter in watts (W) according to the transmitter manufacturer.

■ **Note1:** At 80 MHz and 800 MHz, the separation distance for the higher frequency range applies.



■ **Note2:** These guidelines may not apply in all situations. Electromagnetic propagation is affected by absorption and reflection from structures, objects and people.

注意事项	49
免责声明	50
1. 警告, 注意和提醒	50
2. 规格	51
3. 零件说明	54
4. 设定	56
5. 操作	58
6. 维修和更换零件	61
7. 保养和检查	64
8. 异常排除和故障码	65
9. 工具和消耗品	67
10. 服务联系	68
11. 电磁兼容性资讯	69

注意事项

大多数操作和维护问题都是因为忽略最基本的安全预防措施, 并且没有能够预见到事故的问题和事故的可能性。要避免问题产生与危险的可能性请按照制造商的建议操作。首先仔细阅读所有有关安全和事故预防和注意事项: 然后在操作上需谨慎, 以防止设备损坏或造成人身伤害。

注意下列符号和用语的含义:

	警告	严重受伤或设备损坏或故障或引起火灾的危险
	注意	使用不适当的方法或工具来操作设备
	提醒	设备损坏或中等伤害

■ **提醒:**

此提醒用户相关的操作要点。

用户(即诊所, 医院等)负责管理, 维护和使用此保养设备。除非具有专业资格的牙医或护士, 其余人都不适合操作此设备。

切勿把此设备用于非预期用途。

■ **注意:**

美国联邦法律规定, 此设备只能出售于有合格专业证书的牙医。

注意

TTBIO对于从事下面事项而造成设备损坏，将不负责任

- (1) 由未经TTBIO授权的人员进行维修。
- (2) 任何变更，修改或改变此产品。
- (3) 维护或修理使用非TTBIO生产的零件或部件，而导致原始设定条件失效。
- (4) 使用非此手册提到的操作程序或没有遵守本手册中提到安全注意事项和警告。
- (5) 工作场所的条件和环境，或安装条件不符合本手册中所规定的条件。
- (6) 火灾，地震，洪水，雷电，自然灾害，或不可抗力之因素。

1. 警告，注意和提醒

警告

- 爆炸危害。使用时不要靠近火源或其他点火源。
- 健康危害。通风必须保持良好。因为吸入过多的烟雾可能会损害您的健康。
- 设备电源必须正确的连接。
- 电源接地需正确且妥善的连接与建立。
- 为了防止危及生命的疾病或病菌蔓延，如爱滋病和B型肝炎，在使用TTcare100+后，牙科手机需进行高温灭菌消毒。
- 避免触电的风险。设备损坏和火灾与雷电期间：关闭TTcare100+电源，且不要触摸它或电源线。
- 操作或清洁TTcare100+时，请戴上手套，口罩和防护眼镜。

注意

手机，收发器，遥控器和类似的装置有可能会引起电磁波干扰，造成设备错误。在靠近工作区会发射电磁波的相关装置都必须被关闭。

提醒

- 不同的牙科手机和快速接头，所释放的油雾会不一样。减少油雾的产生可调降压力为最低的设定值4bar。
- 保养油罐安装不正确，会导致保养油泄漏或是无法顺利出油。
- 筒夹保养时需确定牙科手机的筒夹有对准喷嘴。如果倾斜，会导致保养油喷射出来。
- 在保养未完成（蜂鸣声）前，就把牙科手机从接头拆下，会导致保养油从接头喷射而出。

- 对于某些牙科手机，在钻针没有安装的情况下，油雾可能会被散出。
- 将牙科手机安装到设备的接头时，请不要损坏上面的O型环。这会导致保养油泄漏而使保养效果不佳。
- 不要选择一个跟手机不相配的快速接头，这会导致在按下启动开关后保养油泄出。
- 如果一段时间不使用此设备，请将连接此设备，诊所内的主空气阀关闭。
- 请确认您使用正确的电源供应于TTcare100+。
- 不要使用非TTBIO生产的快速接头于TTcare100+，这可能会导致释放油雾过多 或牙科手机保养不佳。
- 根据当地医疗废弃物法规处置用过的吸油垫。
- 请将集油盘完全推入，否则过多的油与油雾可能泄漏。

2. 规格

产品名称	TTcare 100+
电压与频率	AC 100-240 V 50/60 Hz
电力消耗	60VA max.
保险丝	250V 2A Slow Blow Type
压力需求	4~6 bar
建议压力	4 bar
空气流量	40 NL/ min
重量	9 kg
尺寸（宽 / 高 / 深）	295 ×385 ×295 mm
保护等级（防尘防水）	IP20

工作环境要求

位置	只允许在室内使用
环境温度	15 to 40°C (59 to 104°F)
相对湿度	25 to 90 %
最大海拔高度	2000 m (6560 feet)

储存及运输环境

环境温度	-20 to 70°C (-4 to 158°F)
相对湿度	5 to 95 %
大气压力	700 to 1060 hPa

■ 产品说明

用于保持牙科手机最佳性能和延长工作寿命。
自动提供保养油和空气于润滑清洁牙科手机。
用于牙科治疗后，灭菌前。

■ 废弃物处置

废弃物必须在不伤害人类和环境的方法下回收处理：请遵照当地国家的法规进行。
到了寿命使用期限时，设备和配件的处置：

根据2002/96/EC的废电气电子设备指令，指出本产品标签目前遵守其规定，但未受限于此指令处置要求，然而，本产品可能由欧洲特殊废弃物管理中心处理，其他的资讯可透过制造商或牙科供应商取得。

■ 符号的意义

• 设备标签

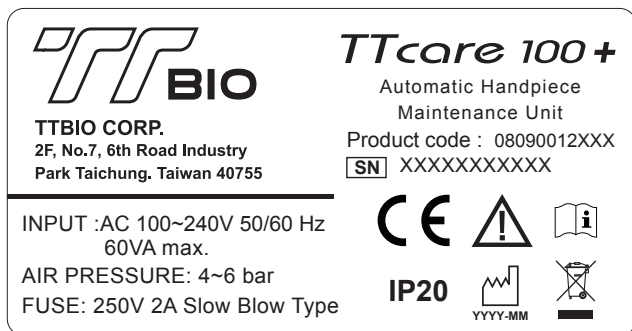

	WARNING
<ul style="list-style-type: none"> The blister can be cleaned with 30°C±5°C tap water or 60% to 70% alcohol, non-high-temperature cleaning. The blister can be used repeatedly, but should be changed once broken. 	

	FLAMMABLE
<ul style="list-style-type: none"> Spray cans will explode if they get too hot. Do not expose the spray cans to heat. Only use approved spray can. <p>* PREVENT EXPLOSION AND IGNITION OF SPRAY CANS!</p>	

• 设备上的符号

	注意操作手册	SN	产品序号
	生产日期		注意
	废弃资讯 参照重要资讯”废弃物处置”		易燃

IP20	保护等级（防尘防水）		护目镜佩戴
-------------	------------	--	-------

• 外箱标签

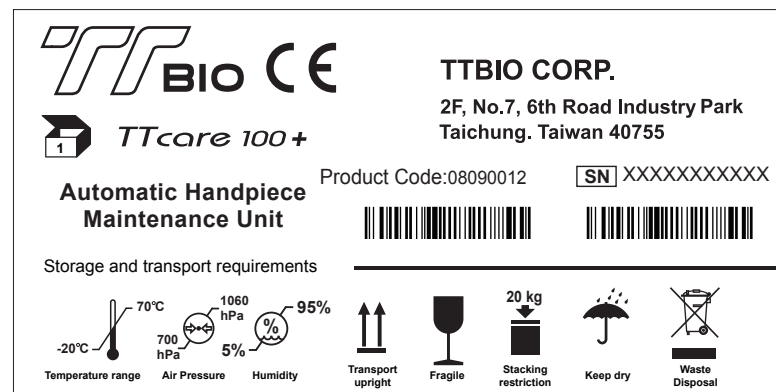

• 包装上的符号

	易碎		气压
	保持干燥		湿度
	垂直运输		数量
	叠放规定		制造商
	温度范围		

■ 主电源开关

	关		开
--	---	--	---

3. 零件说明

■ 介绍

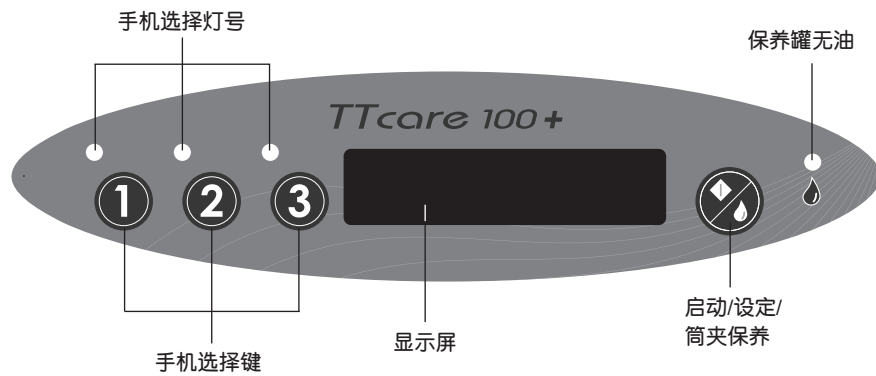
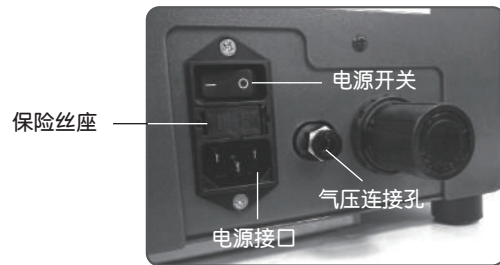
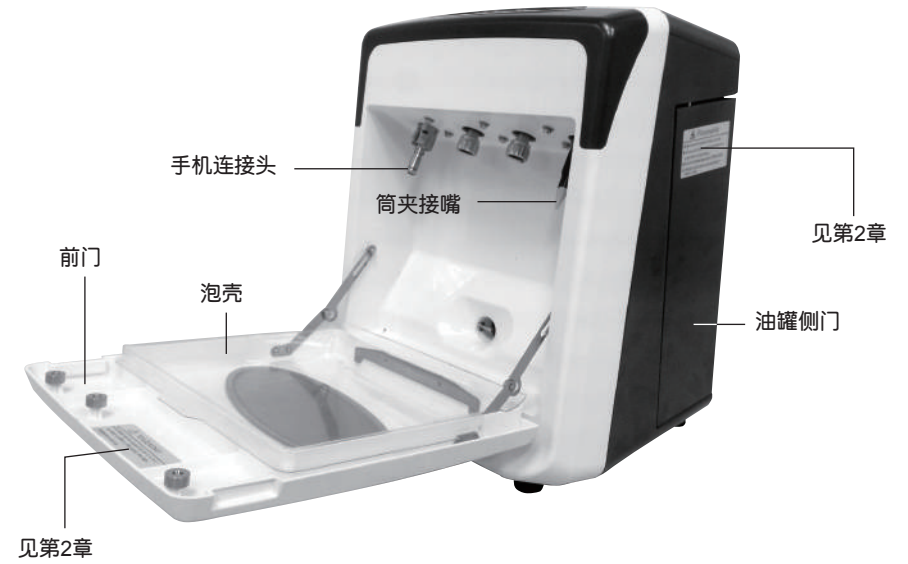

■ 内容物

<p>保养机</p>	<p>泡壳</p> <p>料号: OPL0350</p>	<p>吸油棉</p> <p>料号: OPL0351</p>
<p>集油盘</p> <p>料号: OPL0359</p>	<p>气管</p> <p>料号: OPL0360</p>	

* TTcare 100+ 包含上述标准配备。
* 选购配件, 请参阅第9章。

4. 设定

■ 注意

TTcare100+ 安置至少要离墙面5公分（2英寸）的距离，不可紧贴墙面。

(1) 气压连接

1. 将气压管连接到气压连接孔。打开诊所内的供气阀。

■ 注意

供给的气必须是清洁不含油的。
请确保牢固地连接气压管。



2. 调整气压调整阀，将气源设定4~6 bar。推荐的气压为4 bar。

■ 注意

气压小于4bar或高于6 bar将会发生错误，会产生错误代码并显示于显示屏。



(2) 电源连接

将电源线的一端插入主机，另一端插入电源插座。



■ 注意

确保螺帽是有旋紧的。否则，油和空气会泄漏，而导致保养不完全。



(4) 集油盘

放入两个吸油垫并往后推到底。

■ 注意

集油盘需正确放入，否则，它会导致泄漏。

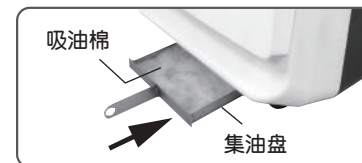

(5) 喷罐

1. 打开油罐侧门。

按下PUSH标志，如右图所示。

■ 注意

不要使用含有酸性或硷性的清洁剂，它会损坏TTcare100+和牙科手机。



2. 确定如左图中所示的固定杆，它是往左边的，然后放入保养油罐。

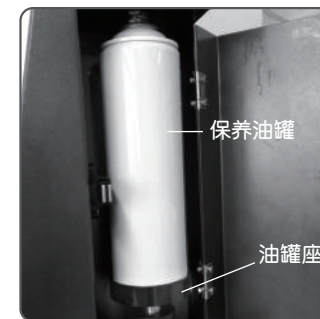
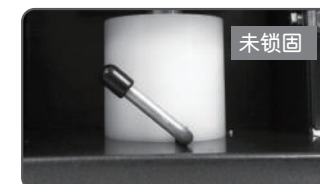

3. 将固定杆往右边推，使得油罐被固定，如右图所示。

■ 注意

确定油罐喷嘴与保养罐是对正的。
确定固定杆如右图所示，是往右的，否则油会不出来。
可轻轻拉一拉喷雾罐，确定它是稳固不会晃动的。

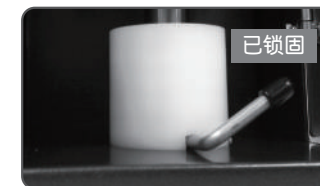

! 注意

若是油罐没被正确的安装，它将会造成泄漏。

4. 轻轻抬起喷雾罐，确认油罐喷嘴是否被固定，如下图所示。



5. 如果油罐是松动的，可使用六角板手调整如右图所示的螺丝。

■ 注意

可调整的高度距离约5mm。

注意

- 建议使用TTBIO生产的 TTlube保养罐。
- 油罐喷嘴和油罐座的设计可相容于某些品牌的保养油罐，但不代表所有的保养油罐都可用。



6. 关上油罐侧门。

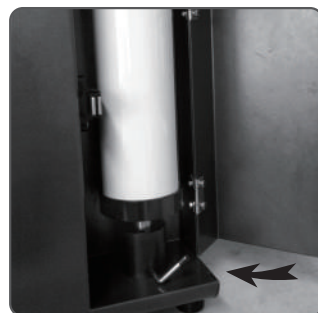

5. 操作

■ 面板显示

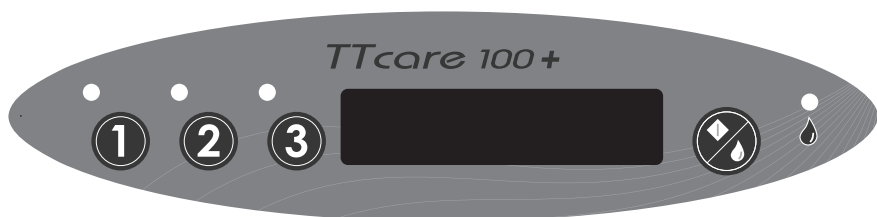

■ 操作指令

图示	功能	操作指令	
	电源开关		关
			开
	1号手机	当选择1号时灯会亮起	
	2号手机	当选择2号时灯会亮起	
	3号手机	当选择3号时灯会亮起	
	开始 / 设定 / 筒夹保养	1. 门关闭时，进行牙科手机保养 2. 门打开时，进行筒夹保养 3. 无任何灯号亮起时，长按进入功能设定	
	保养油耗尽	当灯号亮起代表油罐无油请更换	

■ 操作显示说明



■ 保养操作

■ 注意

- 高速手机与弯手机
保养时移除手机上的钻针
- 直手机
保养时手机上插入钻针并锁上

(1) 筒夹保养:

打开电源, 打开前门。

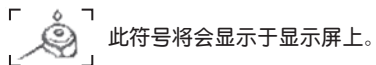

将筒夹对准于设备喷嘴的出口。

按下 进行保养, 发出“哔”声代表完成保养。

(2) 手机保养:

打开电源, 打开前门。

将手机连接到设备的保养接头上, 请确认连接是有牢固的。



选择有接手机的位置, 并按下 / / 进行保养,

发出“哔”声代表完成保养。

■ 注意

保养过程中, 按下任意键或打开前门, 保养将马上停止。

■ 功能设定:

长按 键约2秒, 进入设定功能。

- (1) 气源输入 ON/OFF, 按下 可做切换。
- (2) 保养吹气时间, : 15秒, : 20秒, : 30秒。
- (3) 蜂鸣器响声 ON/OFF, 按下 可做切换。

(4) 辅助马达 ON/OFF, 按下 可做切换。

(5) 辅助马达运转选择, 按下 / / 来各别选择需要启动的手机。

(6) 气源输入显示, 按下 确定。

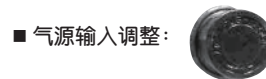

■ 气源输入调整:

拉起压力调整阀 然后转动, 调整压力在4.0~6.0 bars。建议压力为4.0 bars。

按下 键确定。

■ 保养油量调整:

(1) 开机后, 在 和 的指示灯号一起全亮时, 按下 键,



(2) 总共有PU-00到PU-10共11段油量可供调整。按下 为增加, 按下 为减少, 选择你所需的油量后, 按下 键确定储存便会自动回到主画面。

6. 保养和更换零件

■ 更换保险丝



- (1) 使用一字起子压住保险丝座。
- (2) 拉起保险丝。
- (3) 更换保险丝 (规格: 250V 2A Slow-Blow type)
- (4) 将更换完毕的保险丝座插回。

■ 移除和清洁泡壳

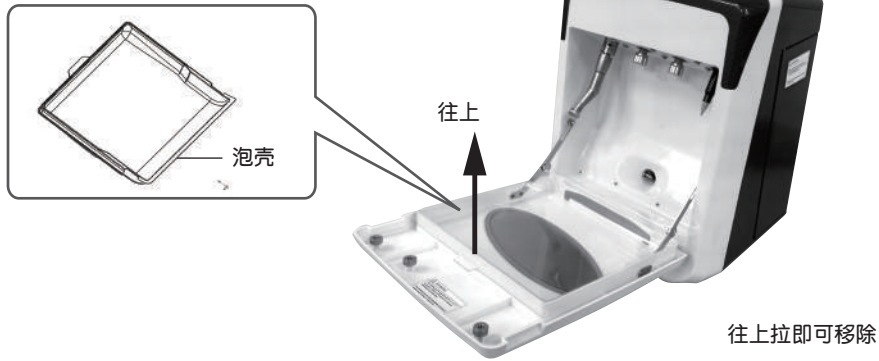

警告

- 此泡壳仅能用30°C±5°C的自来水清洗，或是60~70%的酒精擦拭，不能高温清洗。
- 此泡壳能反覆使用，但若有破损请更换，否则会导致保养油泄露出。

■ 移除和清洁前门

- (1) 往上拉起左边门枢再往内靠。
- (2) 往上拉起右边门枢再往内靠。

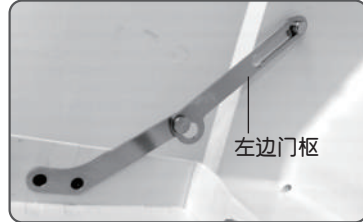

- (3) 将前门拉杆往右图所示的方向拉。
- (4) 便可移除前门。

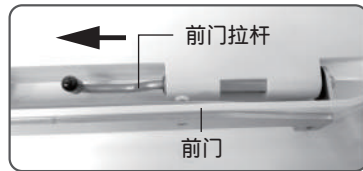

此前门仅能用30°C±5°C的自来水清洗，或是60~70%的酒精擦拭，不能高温清洗。



■ 清洁油盘

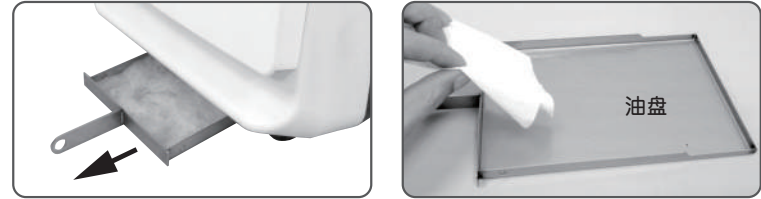

- (1) 将油盘往上图所示的方向拉出。
- (2) 清洁和更换新的吸油棉。

注意

- 此油盘不能高压灭菌。
- 高压灭菌会导致生锈。
- 切勿使用含氯清洁剂或氯化消毒剂擦拭清洗。
- 如果没有清理油盘，将会导致保养油泄露出。

提醒

- 使用过的吸油棉需根据当地医疗废弃物相关法规处理与回收。
- 油盘需往内推到底，否则保养油会泄露出。

■ 清洁快速接头

旋开螺帽后往下拉移除，如右图所示。

■ 提醒

- (1) 移除时请小心不要损坏到O型环。
- (2) 快速接头不能高压灭菌。

可使用60~70%的酒精擦拭。

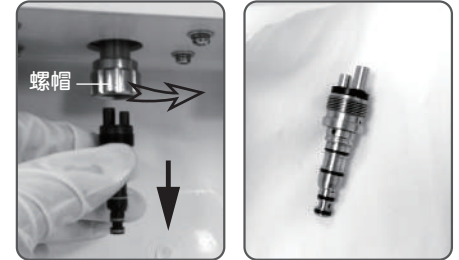

O型环可以从沟槽中被拉出来。

在插入手机前，请确认所有的O型环是有被固定在在凹槽的。

■ 提醒

当O型环没被正确安装在沟槽时，请不要连接手机，这可能导致O型环会卡在手机内部，以致于手机难以卸除。



7. 保养和检查

* 每2年将产品送回检查。

安全检查会依据各国医疗装置法规而不同。可遵照国家法规进行。

* 维修及保养工作，可参照书中所描述的方法来执行，但只可以由合格的技术人员进行。

* 预计使用寿命5年。

- 在透过第三方修改的情况下，现有的医疗器械许可证将会变得无效。
- 只能使用原厂配件和维修备件。
- 使用者（如：诊所，医院等）负责此设备的管理，维护和使用。

■ 定期检查

* 维护和检查通常被认为是使用者的责任和义务，但如果由于某种原因，用户无法执行这些工作，可委托合格的医疗器械维修人员。请联系您当地的经销商或TTIBO股份有限公司。如下详细资料。

- (1) 电源线
目视检查是否有磨损和断线。
- (2) 主要操作开关
打开主开关，并确定电源灯有亮起。
确认设备主机可以正常运行工作。
- (3) 吸油棉
更换吸油棉（当油盘充满油时）。

- 须定期更换零件
保险丝
- 其它更换零配件
吸油棉，泡壳

8. 异常排除与故障码



■ 异常排除

故障	原因	排除方式
主电源灯不亮	电源线没有插入电源插座	正确安装电源线
	电源线没有插入TTcare100+	
按下开始键无法启动 (1) 发出响声 (2) 保养罐无油	前门被开启	关闭前门
	空油罐	更换油罐
	油罐未正确安装	正确安装油罐
	气源没有连接	连接气源
不寻常的气味 表面异常脏污	气源没有正确设定	正确设定气源
	没有连接手机	连接手机
	吸油棉已饱和	清洁TTcare100+和更换吸油棉
	油罐未正确安装	正确安装油罐
未安装油罐 油从油罐溢出	气源没有正确设定	正确设定气源
	油罐的喷嘴弯曲	更换油罐
油泄漏出 设备表面都是油	错误的油罐座	使用正确的油罐座
	手机或接头类型	某些手机和接头类型，有可能会导致油雾释放过多。在这种情况下，请降低压力为4bar
	气源过高	设定气源但不低于4 bar
	无钻针插入	请参照手机的用户指令。对于某些牙科手机，如果未插入钻针会导致油雾散出。

■ 故障码

错误码	说明	原因	排除方式
Error 01	按键错误	功能键故障	请与经销商联系
Error 02	供油马达错误	马达损坏或内部电流错误	请与经销商联系
Error 03	辅助马达错误	马达损坏或内部电流错误	请与经销商联系
Error 04	气压过低	气源压力设定过低	调整增加气源 (设定请见第4章)
Error 05	气压过高	气源压力设定过高	调整减少气源 (设定请见第4章)
Error 06	功能记忆错误	电子IC损坏	请与经销商联系
Error 07	无油	空油罐	更换新油罐 请与经销商联系
Error 08	电磁阀错误	电磁阀故障	请与经销商联系
Error 09	电流过高	马达损坏或内部电流错误	请与经销商联系
Error 10	电流侦测错误	电子IC损坏	请与经销商联系

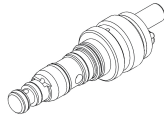
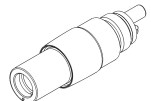
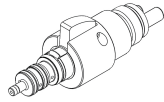
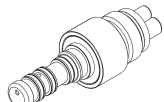
9. 工具和消耗品

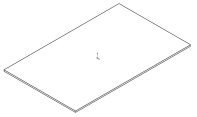
图示	说明	料号
	保养接头 KaVo	0PL0345
	保养接头 W&H	0PL0346
	保养接头 NSK	0PL0344
	保养接头 Bien-Air	0PL0348
	保养接头 SIRONA	0PL0347
	保养接头 E-Type	0PL0349
	TTlube 保养油罐	08090011
	泡壳	0PL0350
	吸油棉	0PL0351

10. 服务联系

■ 对于维修或其他类型的服务，请联系您当地的经销商或TTBIO CORP。

■ 医疗设备的处置

任何被污染的医疗设备都必须先由负责的医生或医疗机构先清洗，再交于有合格处理医疗废弃物和工业废弃物的机构。

11. 电磁兼容性资讯

Guidance and manufacturer's declaration-electromagnetic emissions

The TTcare 100+ is intended for use in the electromagnetic environment specified below.
The customer or the user of the TTcare 100+ should assure that it is used in such an environment.

Emission Test	Compliance	Electromagnetic environment-guidance
RF emissions CISPR 11	Group 1	The TTcare 100+ uses RF energy only for its internal function. Therefore, its RF emissions are very low and are not likely to cause any interference in nearby electronic equipment.
RF emissions CISPR 11	Group B	The TTcare 100+ is suitable for use in all establishments, including domestic establishments and those directly connected to the public low-voltage power supply network that supplies buildings used for domestic purposes.
Harmonic emissions IEC 61000-3-2	Group A	
Voltage fluctuations /flicker emissions IEC 61000-3-3	Compliance	

Guidance and manufacturer's declaration-electromagnetic immunity			
The TTcare 100+ is intended for use in the electromagnetic environment specified below. The customer or the user of the TTcare 100+ should assure that it is used in such an environment.			
Immunity test	IEC 60601 test level	Compliance level	Electromagnetic environment-guidance
Electrostatic discharge(ESD) IEC 61000-4-2	± 6 kV contact ± 8 kV air	± 6 kV contact ± 8 kV air	Floors should be wood, concrete or eramic tile. If floors are covered with synthetic material, the relative humidity should be at least 30%
Electrical fast transient/burst IEC 61000-4-4	± 2kV for power supply lines ± 1kV for input/output lines	± 2kV for power supply lines Not applicable	Mains power quality should be that of a typical commercial or hospital environment.
Surge IEC 61000-4-5	± 1kV line(s) to line(s) ± 2kV line(s) to earth	± 1kV differential mode Not applicable	Mains power quality should be that of a typical commercial or hospital environment.
Voltage Dips, short interruptions and voltage variations on power supply input lines IEC 61000-4-11	<5% UT(>95% dip in UT) for 0,5 cycle 40% UT(60% dip in UT) for 5 cycles 70% UT(30% dip in UT) for 25 cycles <5% UT(>95% dip in UT) for 5 s	<5% UT(>95% dip in UT) for 0,5 cycle 40% UT(60% dip in UT) for 5 cycles 70% UT(30% dip in UT) for 25 cycles <5% UT(>95% dip in UT) for 5 s	Mains power quality should be that of a typical commercial or hospital environment. If the user of the TTcare 100+ requires continued operation during power mains interruptions, it is recommended that the TTcare 100+ be powered from an uninterruptible power supply or a battery.
Power frequency (50/60 Hz) magnetic field IEC 61000-4-8	3 A/m	3 A/m	The TTcare 100+ power frequency magnetic fields should be at levels characteristic of a typical location in a typical commercial or hospital environment.
<p>■ Note: UT is the a.c. mains voltage prior to application of the test level.</p>			

Guidance and manufacturer's declaration-electromagnetic immunity			
The TTcare 100+ is intended for use in the electromagnetic environment specified below. The customer or the user of the TTcare 100+ should assure that is used in such and environment.			
Immunity test	IEC 60601 test level	Compliance level	Electromagnetic environment-guidance
Conducted RF IEC 61000-4-6	3 Vrms 150 KHz to 80 MHz	3 Vrms	<p>Portable and mobile RF communications equipment should be used no closer to any part of the TTcare 100+ including cables, than the recommended separation distance calculated from the equation applicable to the frequency of the transmitter.</p> <p>Recommended separation distance: $d = 1,2 \sqrt{P}$ $d = 1,2 \sqrt{P}$ 80MHz to 800 MHz $d = 2,3 \sqrt{P}$ 800MHz to 2,5 GHz</p> <p>Where P is the maximum output power rating of the transmitter in watts (W) according to the transmitter manufacturer and d is the recommended separation distance in metres (m).</p> <p>Field strengths from fixed RF transmitters, as determined by an electromagnetic site survey, ^a should be less than the compliance level in each frequency range.^b</p> <p>Interference may occur in the vicinity of equipment marked with the following symbol:</p> 
Radiated RF IEC 61000-4-3	3 V/m 80MHz to 2,5 GHz	3 V/m	
<p>■ Note1: At 80 MHz and 800 MHz, the higher frequency range applies.</p> <p>■ Note2: These guidelines may not apply in all situations. Electromagnetic propagation is affected by absorption and reflection from structures, objects and people.</p>			
<p>■ a: Field strengths from fixed transmitters, such as base stations for radio (cellular/cordless) telephones and land mobile radios, amateur radio, AM and FM radio broadcast and TV broadcast cannot be predicted theoretically with accuracy. To assess the electromagnetic environment due to fixed RF transmitters, an electromagnetic site survey should be considered. If the measured field strength in the location in which the TTcare 100+ is used exceeds the applicable RF compliance level above, the TTcare 100+ should be observed to verify normal operation. If abnormal performance is observed, additional measures may be necessary, such as re-orienting or relocating the TTcare 100+.</p> <p>■ b: Over the frequency range 150 kHz to 80 MHz, field strengths should be less than 3 V/m.</p>			

**Recommended separation distance between
portable and mobile RF communications equipment and the TTcare 100+**

The TTcare 100+ is intended for use in an electromagnetic environment in which radiated RF disturbances are controlled. The customer or the user of the TTcare 100+ can help prevent electromagnetic interference by maintaining a minimum distance between portable and mobile RF communications equipment (transmitters) and the TTcare 100+ as recommended below, according to the maximum output power of the communications equipment.

Rated maximum output power of transmitter W	Separation distance according to frequency of transmitter M		
	150 kHz to 80 MHz $d = 1,2\sqrt{P}$	80 MHz to 800 MHz $d = 1,2\sqrt{P}$	800 MHz to 2,5 GHz $d = 2,3\sqrt{P}$
0.01	0.02	0.12	0.23
0.1	0.38	0.38	0.73
1	1.2	1.2	2.3
10	3.8	3.8	7.3
100	12	12	23

For transmitters rated at a maximum output power not listed above, the recommended separation distance d in metres (m) can be estimated using the equation applicable to the frequency of the transmitter, where p is the maximum output power rating of the transmitter in watts (W) according to the transmitter manufacturer.

- **Note1:** At 80 MHz and 800 MHz, the separation distance for the higher frequency range applies.
- **Note2:** These guidelines may not apply in all situations. Electromagnetic propagation is affected by absorption and reflection from structures, objects and people.